

APPLY LUBRICANT TO ALL SEALS PRIOR TO INSTALLATION. DO NOT USE SILICONE TYPE LUBRICANTS. FOR PROPER ARM MOUNTING SEE IS1505.

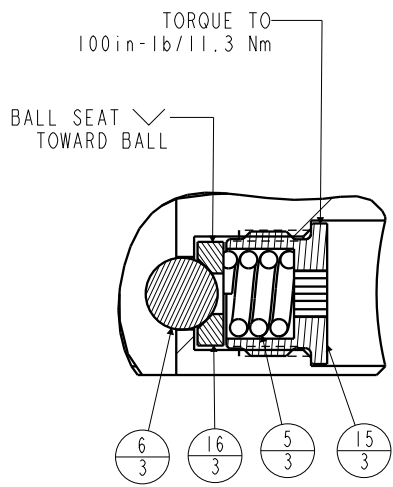

DETAIL A SCALE 1.500

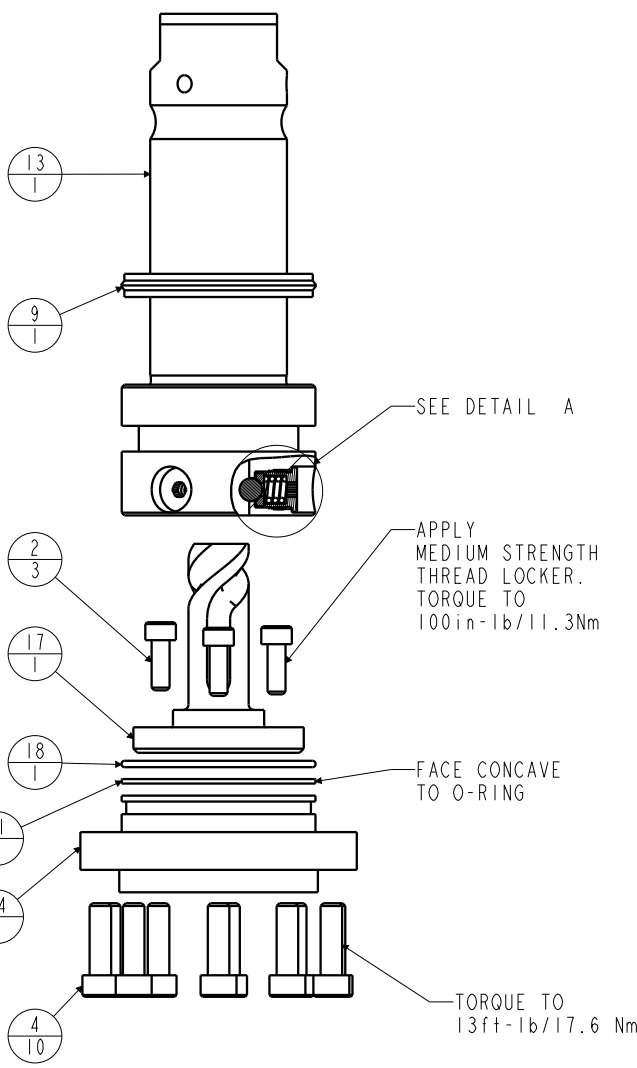

N/A	N/A	IS1505	INSTRUCTION SHEET, ARM INSTALLATION		
N/A	N/A	6V711036	SEAL KIT, FKM		
N/A	N/A	60711036	SEAL KIT, STANDARD		
19	1	39V11051	WIPER,PRESS-IN, (1-1/2)	X	X
18	1	39H51002	O-RING, (-033)	X	39V51002
17	1	81592121	CAM,SC,LP,7500/33KN,RH,TC		
16	3	81532108	SEAT, BALL, SC, LP, TC		
15	3	81532107	RETAINER, SC, LP, TC		
14	1	81532105	CAP, END, SC, LP, 33kN/7500		
13	1	81512111	PLUNGER,SC,LP,7500&33KN,DA,TC		
12	2	43068006	PLUG, 1/4 BSPP MALE		
11	1	39054017	BU RING, (-033)	X	39054023
10	1	39054016	BU RING,(1.5x.125x.063)	X	X
9	1	39052030	SEAL,CROWN,1-3/4x2-1/8x1/4	X	39V52030
8	2	39050042	O-RING, (-011)	X	39051025
7	1	39011075	SEAL, LL, (1-1/2 X 1/8 X 1/8 1-3/4)	X	39V11075
6	3	23650004	BALL,TUNGSTEN-CARBIDE,250		
5	3	23350066	SPRING, COMPRESSION		
4	10	21500304	SHCS, M6 X 1,0-66 X 20MM		
3	2	21500200	WASHER		
2	3	21500031	SHCS, M5 X 0,8 X 14, ALY		
1	2	21500019	SCREW, CAP, BTNH, M3 X 6, ALY		
No.	QTY	PART No.	DESCRIPTION	Std. Seal Kit	FKM Seal Kit

PARTS LIST



VEKTEK, INC.
1334 E. SIXTH AVE. P.O. BOX 625
EMPORIA, KS. 66801 U.S.A.

ASSEMBLIES AFFECTED
41463321
41463321F

PARTS LIST, ASSY,SC,LP,TC,TF,33KN,DA,RH
SIZE A MPL7154 REV C

C	5762	RELEASE	JDW	07/15/25
REV	IN ACCORDANCE WITH ECN	EFFECTIVE DATE	REVISED BY	DATE
DRW BY:	JDW	DRAWING STATUS: Released		
DATE:	6-7-11	PRODUCTION APPROVED FOR RELEASED STATUS ONLY		

